

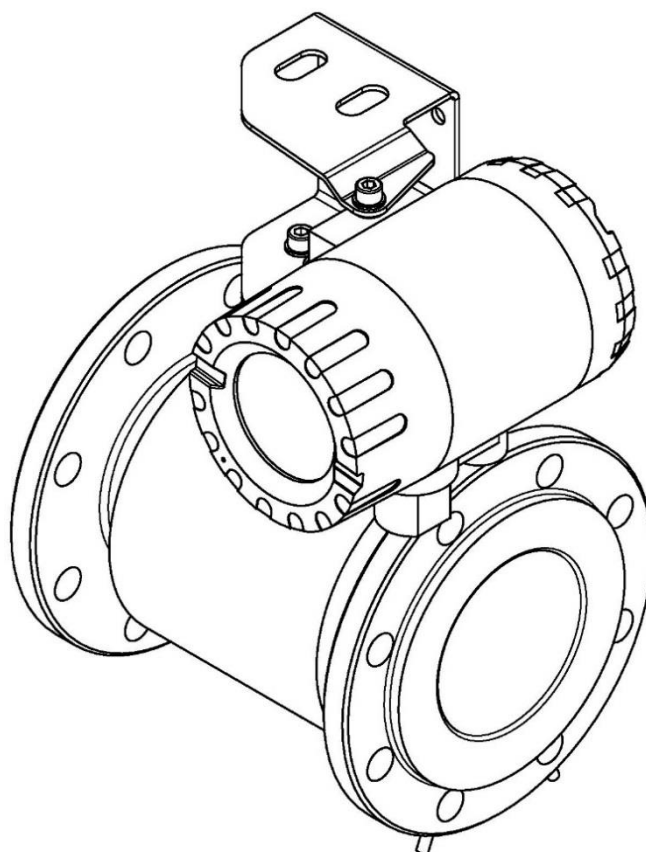



APLISENS[®]

USER'S MANUAL

ELECTROMAGNETIC FLOWMETER **PEM-1000**



Symbols used

Symbol	Description
	Warning to proceed strictly in accordance with the information contained in the documentation in order to ensure the safety and full functionality of the device.
	Information particularly useful during installation and operation of the device.
	Information on disposal of used equipment.

BASIC REQUIREMENTS AND SAFE USE

The manufacturer will not be liable for damage resulting from incorrect installation, failure to maintain a suitable technical condition of the device or use of the device other than for its intended purpose.

Installation should be carried out by qualified staff having the required authorizations to install electrical and I&C equipment. The installer is responsible for performing the installation in accordance with manual as well as with the electromagnetic compatibility and safety regulations and standards applicable to the type of installation.

In systems with I&C equipment, in case of leakage, there is a danger to staff due to the medium under pressure. All safety and protection requirements must be observed during installation, operation and inspections.

If a malfunction occurs, the device should be disconnected and handed over to the manufacturer for repair.

In order to minimize the risk of malfunction and associated risks to staff, the device is not to be installed or used in particularly unfavourable conditions, where the following hazards occur:

- possible mechanical impacts, excessive shocks and vibration;
- excessive temperature fluctuation;
- water vapour condensation, dusting, icing.

Changes made to the manufacturing of products may be introduced before the paper version of the manual is updated. The up-to-date manuals are available on the manufacturer's website: www.aplisens.com.

TABLE OF CONTENTS

1. INTRODUCTION	5
1.1. Trademarks	5
2. SAFETY	5
3. TRANSPORT AND STORAGE	6
3.1. Delivery check	6
3.2. Transport	6
3.3. Storage	6
4. GUARANTEE	6
5. IDENTIFICATION	7
5.1. Manufacturer's address	7
5.2. Flowmeter identification	7
5.3. CE mark, declaration of conformity	8
6. INSTALLATION	9
6.1. General recommendations	9
6.2. Recommended installation methods for flow sensor	9
6.3. Installation of the PEM-1000 flowmeter	11
7. ELECTRICAL CONNECTION	13
7.1. Connecting the sensor signal cable	14
7.2. Grounding	16
7.2.1. Protective grounding	16
7.2.2. Functional grounding	17
8. START-UP	19
9. TECHNICAL PARAMETER	19
9.1. Protection class	19
9.2. Technical specification	19
9.3. Technical specification	20
9.4. Metrological parameters	20
9.5. Table of volumetric flows calculated for the characteristic flow velocities of the medium for versions with flanges according to DIN	21
9.5.1. Selection of flowmeter diameter and measuring range	22
10. MAINTANANCE	24
10.1. Periodic inspections	24
10.2. Non-periodic inspections	24
10.3. Cleaning/Washing	24
11. TROUBLESHOTING	25
11.1. Measurement board error E_FE_xx	25
11.2. Sensor error E_SENS_xx	26
12. SCRAPING, DISPOSAL	26
13. HISTORY OF REVISIONS	26
APPENDIX A – Configuration Local MENU Settings	27
APPENDIX B - Structure of the local MENU	35

LIST OF DRAWINGS

Figure 1. Recommended examples of sensor installation.....	9
Figure 2. Examples of incorrect sensor installation on the site and suggested solutions.	10
Figure 3. Installation of the PEM-1000 flowmeter - examples.....	11
Figure 4. Examples of installation of the flowmeter transmitter in the PEM-1000NW version on a pipe and on the wall.....	12
Figure 5. Electrical wiring from the PEM-1000 transmitter.	13
Figure 6. View of electrical terminals of the PEM-1000 flowmeter.	13
Figure 7. Marking the leads of the sensor cable cores.....	15
Figure 8. Connection pins of the sensor cable plug.	15
Figure 9. Location and method of connecting the protective earth to the transmitter housing.....	16
Figure 10. Proper preparation of the power cable.....	16
Figure 11. Example of a functional earthing connection for a metal pipeline and for an insulated pipeline using earthing rings.	17
Figure 12. The way of connecting the functional ground to the transmitter housing.....	17
Figure 13. The method of connecting functional ground to the sensor housing.	18
Figure 14. Graph of correct functional grounding of the PEM-1000 flowmeter.....	18
Figure 15. Recommended flow values of the PEM-1000 flowmeter.....	22
Figure 16. The measuring range of the flowmeter is determined by the Qmax parameter.	23

LIST OF TABLES

Table 1. Symbols appearing on the flowmeter's nameplate.....	7
Table 2. Symbols appearing on the sensor's nameplate.....	8
Table 3. Designation of connection terminals of the PEM-1000 flowmeter.....	14
Table 4. Connection pins of the sensor cable plug.....	15
Table 5. Technical data of the sensor and transmitter.	19
Table 6. Flow values for the PEM-1000 flowmeter.....	20
Table 7. Volumetric flow as a function of the linear velocity of the medium.	21
Table 8. Flow values corresponding to a speed of 1 m/s.	22
Table 9. Error descriptions of the PEM-1000 flowmeter and their possible solutions.....	25

1. INTRODUCTION

The subject of manual are electromagnetic flowmeters in two versions:

- A compact version designated **PEM-1000ALW** - with transmitter placed directly on the measuring sensor;
- A remote version designated **PEM-1000NW** - with transmitter connected via cable and placed up to 50 m from measuring sensor.

The manual contains data, guidelines and recommendations concerning installing and operating, as well as procedure in the event of a failure.



The description of device configuration can be found in the EN.IK.PEM-1000 configuration manual, and the Modbus communication is described in the IM.PEM-1000(ENG). They are available on the manufacturer's website www.aplisens.com

1.1. Trademarks

Modbus® is a service registered and managed by SCHNEIDER AUTOMATION, INC..

2. SAFETY



- The installation and start-up of the device and any activities related to operation shall be carried out after thorough examination of the contents of user's manual and the instructions related thereto;
- installation and maintenance should be carried out by qualified staff having the required authorizations to install electrical and measuring devices;
- the device shall be used according to its intended purpose in line with the permissible parameters specified on the nameplate (→ [Flowmeter identification](#));
- the protection elements used by the manufacturer to ensure transmitter safety may be less effective if the device is operated in a manner not consistent with its intended purpose;
- before installing or disassembling the device, it is absolutely necessary to disconnect it from the power source;
- no repairs or alterations to the transmitter electronic system are permitted. Assessment of damages and possible repair may only be performed by the manufacturer or authorized representative;
- do not use instruments if damaged. In case of malfunction, the device must be put out of operation;

3. TRANSPORT AND STORAGE

3.1. Delivery check

After receiving the delivery of the equipment, it is necessary to:

- make sure that the packaging and its contents were not damaged during transport;
- check the completeness and correctness of the received order, and make sure no parts are missing.

3.2. Transport

Transport of flowmeters shall be carried out with the use of covered means of transport, in original packages. The packaging shall be protected against movement and direct impact of atmospheric factors.

3.3. Storage

Flowmeters shall be stored in a factory packaging, in a room without vapours and aggressive substances, protected against mechanical impact.

Allowable range of ambient and storage parameters:

Allowable range of ambient/storage temperature	-20 ... 60°C (-4 ... 140°F)
Relative humidity	to 80%
Surrounding atmosphere	No aggressive ingredients
Height above sea level	to 2000 m



The permissible ambient and device operating parameters must not be exceeded. Exceeding them may result in an increase in measurement errors.

4. GUARANTEE

General terms and conditions of guarantee are available on the manufacturer's website:

www.aplisens.com/ogolne_warunki_gwarancji



The guarantee shall be repealed if the device is used against its intended use, failure to comply with user's manual or interference with the structure of the device.

5. IDENTIFICATION

5.1. Manufacturer's address

APLISENS S.A.
03-192 Warsaw
Morelowa 7 St.
Poland

5.2. Flowmeter identification

Table 1. Symbols appearing on the flowmeter's nameplate.









	Logo and name of manufacturer.
	CE mark.
03-192 WARSZAWA Morelowa 7 Poland tel.: +48 22 814 07 77	Manufacturer's address.
Type	Flowmeter type .
Qmin / Qmax	Min/Max of flow value.
Power supply	Supply voltage values.
Output	Output signal.
# S/N	Serial number of flowmeter.
Sensor no.	Serial number of sensor.
Year of production	Year of production.
IP	IP protection rating.
	Note about the obligation to read the manual.
	Information on dealing with used equipment.

Table 2. Symbols appearing on the sensor's nameplate.

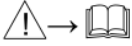
	Logo and name of manufacturer.
CE	CE mark.
Type	Sensor type.
No.	Serial number of sensor.
Year of production	Year of production of the sensor.
Lining mat.	Sensor lining.
Electrode mat.	Electrode material.
IP	IP protection rating.
A= B=	Value of calibration coefficient A and B.
	Information on dealing with used equipment.
	Note about obligation to read the manual.
	Direction flow of medium.
Aplisens S.A. ul. Morelowa 7, 03-192 Warszawa	Manufacturer's address.

5.3. CE mark, declaration of conformity

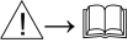
The device has been designed to meet the highest safety standards, has been tested and has left the factory in a condition that is safe for operation. The device complies with the applicable standards and regulations listed in the EU Declaration of Conformity and has CE marking on nameplate.

6. INSTALLATION

6.1. General recommendations

- It is recommended that the flow direction is in the direction of the arrow on the sensor, the transducer is also factory set to work in this direction. The flow in the opposite direction to the arrow is shown as a negative value. If it is necessary to mount the sensor upside down, please contact the manufacturer.
- Before installation, check if there is enough space next to the flange for installing the flow meter with the use of bolts and nuts.
- During the measurement, the entire space inside the sensor should be filled with the measured liquid.
- Fix the pipework on both sides of the flowmeter to avoid vibration and sag in the pipework from affecting the measurement.
- If the flowmeter is installed in a pipeline with a larger ID, use a reducer that ensures axial fixation without increasing stress on the sensor pipes and flanges. Remember to keep straight sections in front of and behind the sensor.
- During installation the straight sections should be of nominal diameter of the sensor (DN) with lengths of at least 5DN before and 3DN after the sensor.
- When installing the sensor on an insulated pipe (e.g. glass, plastics etc.) please insulate the system with earthing rings connected with ground terminal of the sensor → [Figure 11](#).
- Conductive connection between ground (enclosure) of the sensor and liquid is necessary for correct measurements.
- During assembly it is essential to install a seal between the flanges of the sensor and the piping. When using grounding rings, seal use rings on both sides.
- Do not use gaskets made of hard materials as they may damage the Teflon lining or, in the case of rubber lining, fail to ensure a sufficient tightness of the installation.
- Make sure that no sealing element enters the lumen of the pipeline as this may introduce turbulence into the flow and disrupt the operation of the flowmeter.

6.2. Recommended installation methods for flow sensor

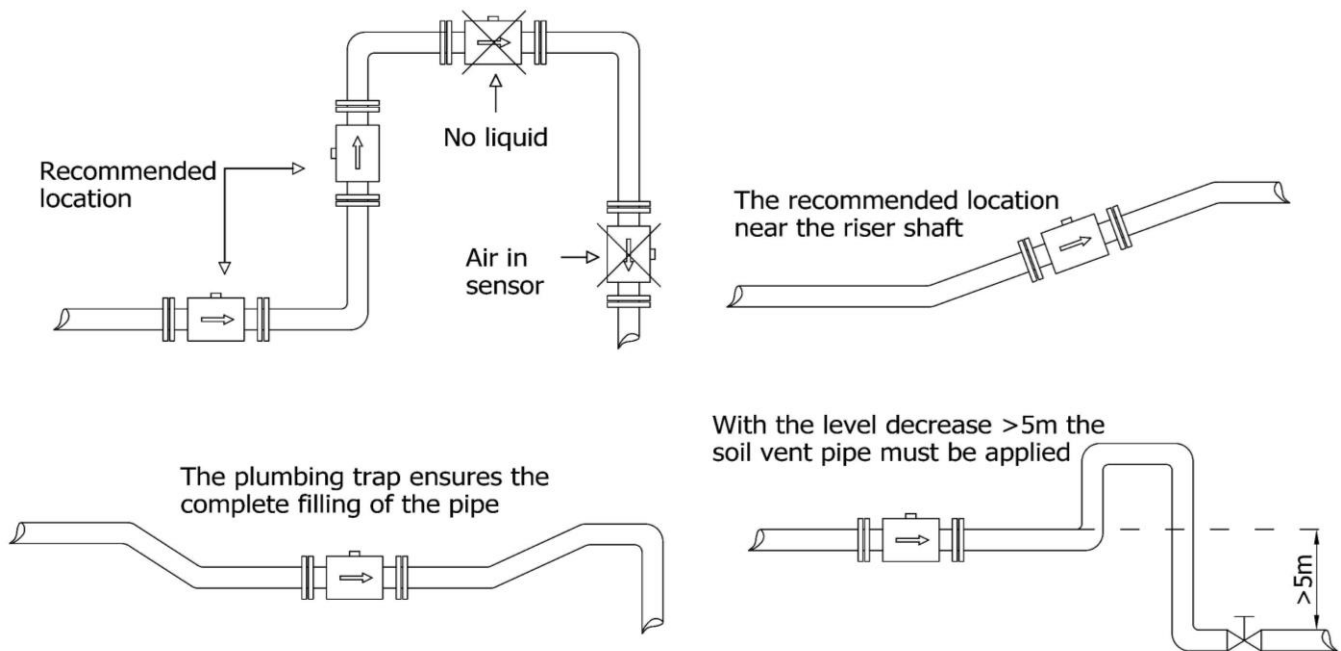

Figure 1. Recommended examples of sensor installation.

To avoid metrological errors caused by air bubbles or damage floor covering, follow the recommendations below:

- during installation, properly position the sensor, tighten the flange bolts simultaneously on both sides;
- it is recommended that the flowmeter is installed so that the electrode axis is as horizontal as possible, in accordance with the examples → **Figure 3**. Installation of the PEM-1000 flowmeter - examples.
- Teflon lining requires special care during handling and assembly. During installation (operation), avoid excessive under pressure in the pipeline. Do not damage liner leads to the outer flange surfaces on both sides of the sensor. Some sensors are delivered from the manufacturer with special covers that prevent the deformation of the Teflon lining. Covers should be removed immediately before installation, before placing between the counter flanges;
- ensure that no seal element enters the lumen of the pipeline, as this may introduce turbulence into the flow and disturb the flowmeter.

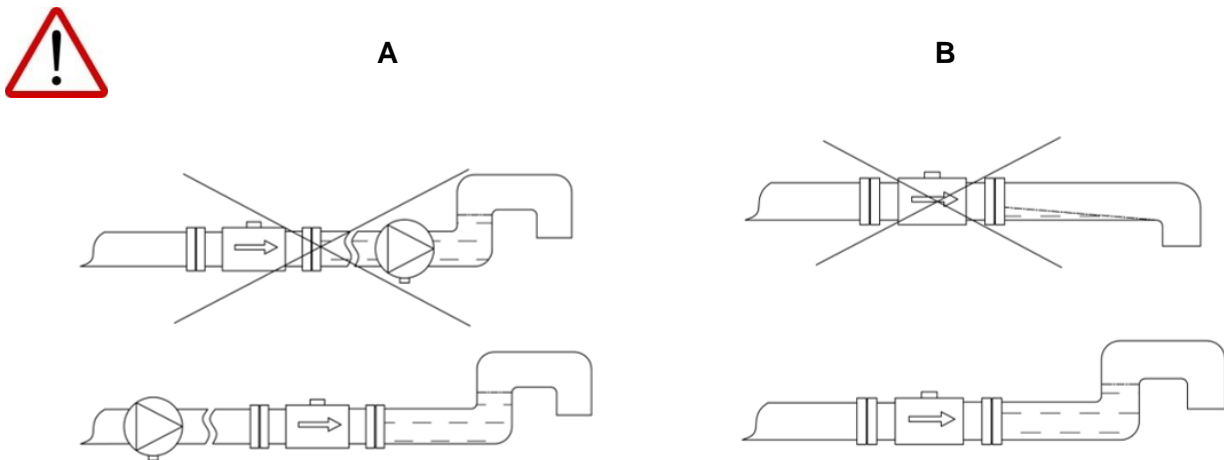

Figure 2. Examples of incorrect sensor installation on the site and suggested solutions.

The figure shows the two most common cases of incorrect installation of a flowmeter sensor on a facility.

Case A shows incorrect installation of the pump (behind the sensor). This type of mounting can cause distortion of the flow values and also expose the electrodes, which can result in an error of empty pipe detection. In extreme cases the vacuum generated by the pump can damage the sensor lining.

Case B shows the sensor mounted at the end of the pipeline. This way of mounting may cause the electrodes to be exposed, which will result in a distortion of the flow, as well as the ingress of air and drying up of the medium on the inner walls of the sensor. In order to avoid problems with the functioning of the device, it is recommended to use a siphon as shown in the picture.

6.3. Installation of the PEM-1000 flowmeter

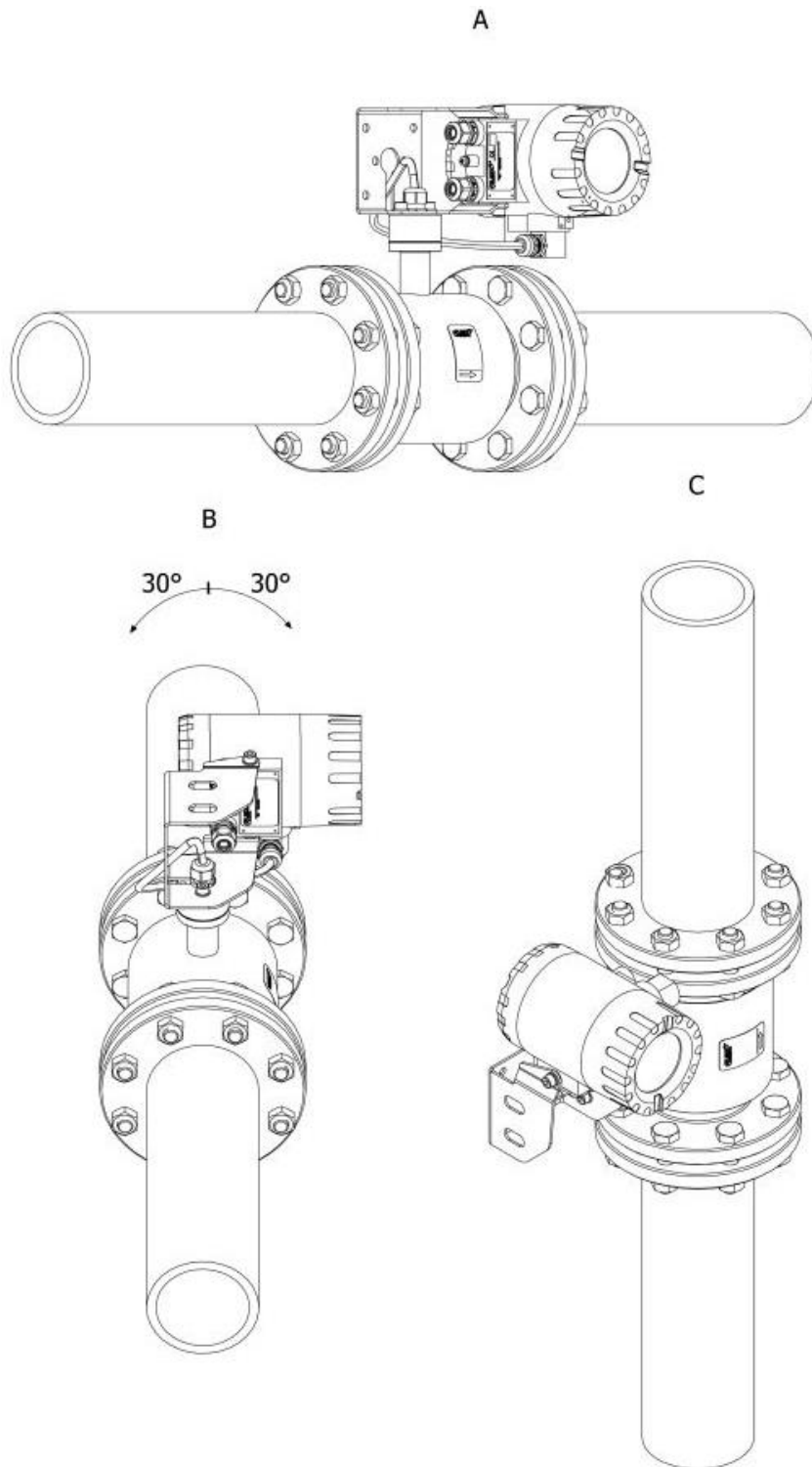

Figure 3. Installation of the PEM-1000 flowmeter - examples.



It is recommended to install the flowmeter in a horizontal position (A), with the possibility of tilting it by about 30° (B) and in a vertical position (C) - according to the examples shown in the figure. Otherwise there is a possibility of disturbing the measurements or issuing an alarm of empty pipe detection when there is air in the system (one of the electrodes will be uncovered).

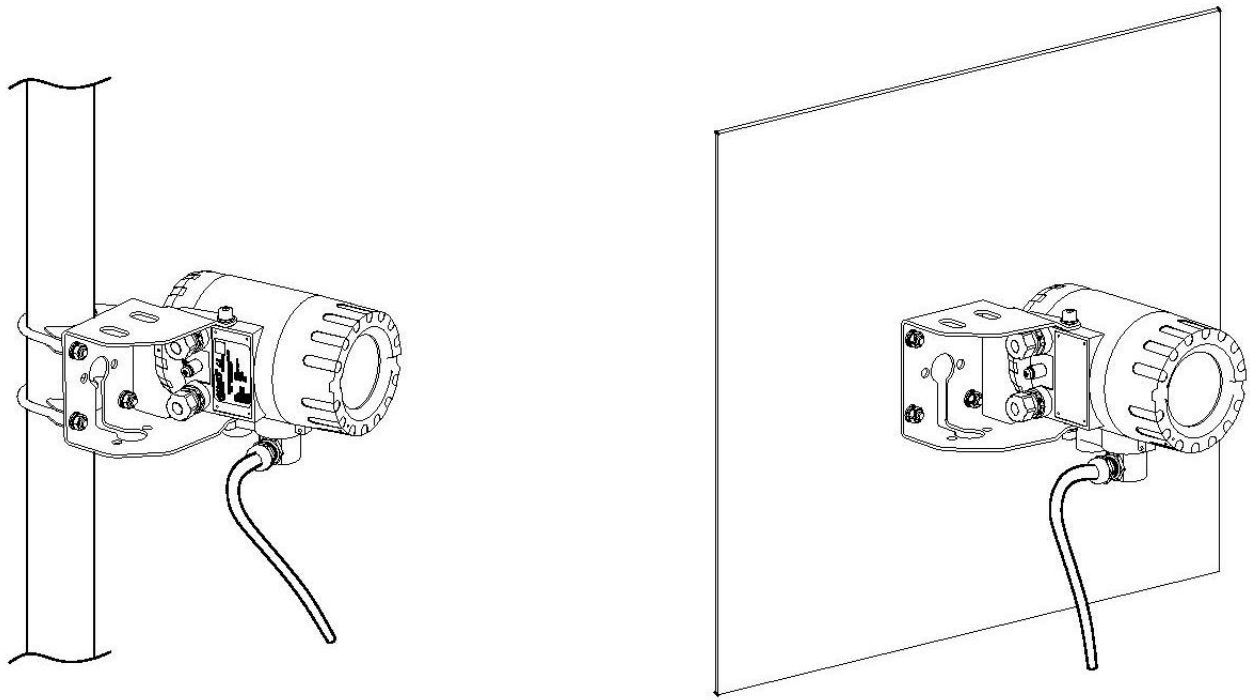

Figure 4. Examples of installation of the flowmeter transmitter in the PEM-1000NW version on a pipe and on the wall.

7. ELECTRICAL CONNECTION



All connection and assembly operations must be performed with the supply voltage and other external voltages, if used, disconnected. In the close vicinity of the flowmeter transducer (in the same room), install a circuit breaker on the flowmeter supply line with protection. It should be easily accessible and clearly and unambiguously marked with symbols complying with local regulations for safety of electrical equipment.

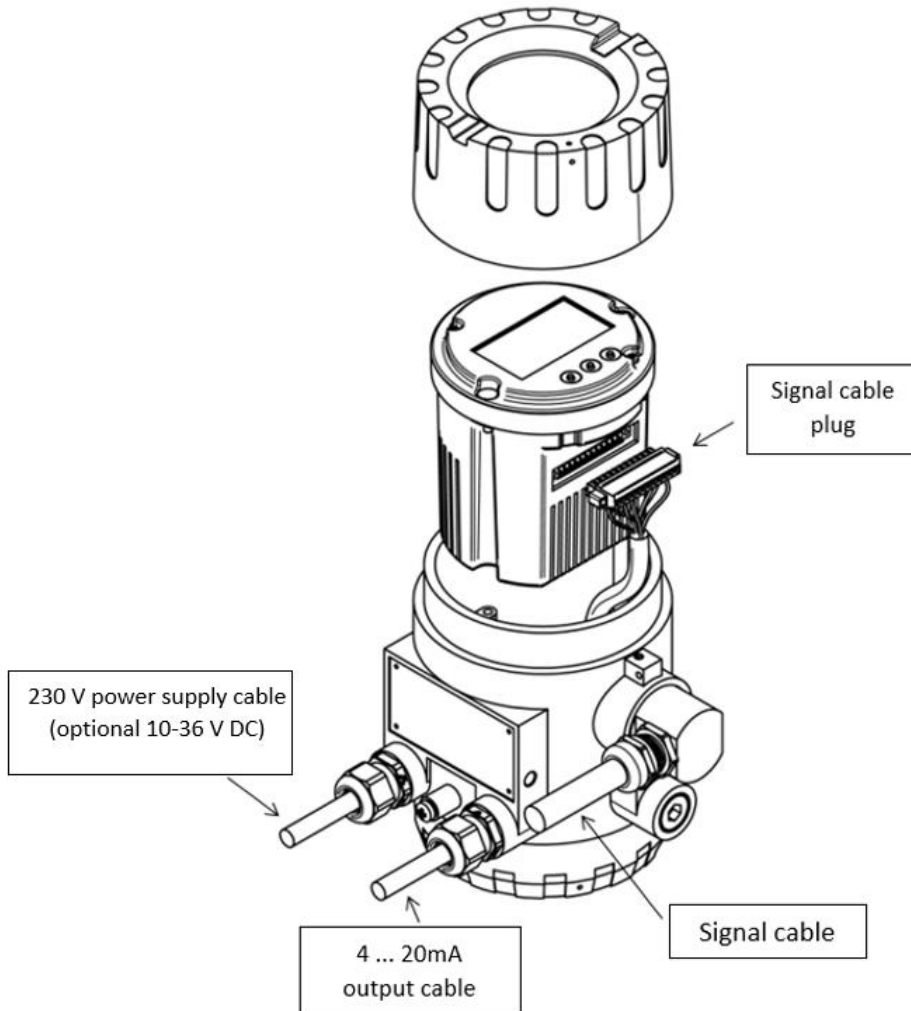

Figure 5. Electrical wiring from the PEM-1000 transmitter.

Electrical terminals of the flowmeter can be accessed by unscrewing the side cover of the side cover of the transmitter casing. The figure and table below show the arrangement and purpose of the individual terminals.

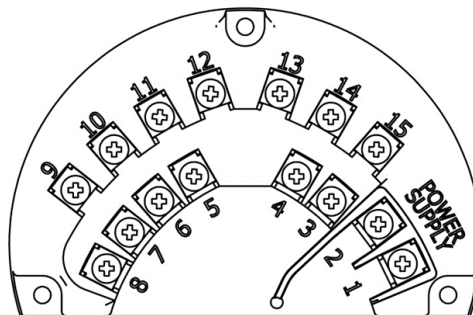

Figure 6. View of electrical terminals of the PEM-1000 flowmeter.

Table 3. Designation of connection terminals of the PEM-1000 flowmeter.

	Terminal No	Description		
Power supply	1	mains supply	(-)	Low voltage power supply DC (option)
	2		(+)	
Binary output 1	3	Any polarization		
	4	Galvanically isolated, passive		
Pulse output/ frequency	5	passive		
	6	any polarization, galvanically isolated		
Analog current output 4÷20 mA	7	(+)	active / passive (default active)	
	8	(-)		
Communication	9	RS 485 A	port galvanically isolated, ground should be connected	
	10	RS 485 B		
	11	RS 485 ground/shield		
Binary input passive	12	Any polarisation		
	13	galvanically isolated		
Binary output 2	14	Any polarisation, galvanically isolated		
	15	passive		



In order to maintain security of the supply lines and output lines should be carried within the housing separate glands.

The cables (lines) attached to the screw terminals should be terminated with end sleeves 0.75 mm². When connecting the flowmeter to the power supply, observe the following rules:

- connections of electrical appliances;
- protection against electric shock;
- principles of safe operation of electrical installations by personnel.

The electrical protection of the device allows it to be used in various environments, and in consultation with the manufacturer, it is possible to make additional modifications that allow it to be used in specific user environmental conditions. The output cables from the converter should not be led next to power cables and other cables that may generate interference. Devices cooperating with the flowmeter should be resistant to electromagnetic disturbances generated in the environment, in accordance with the compatibility requirements in force in the place of use.



Power supply of the transducer with a low-voltage power supply (optional version) is connected to the same POWER SUPPLY terminals as the mains power supply (plus terminal no. 2). The low-voltage power supply is protected against incorrect power polarity. Do not connect the mains power to the POWER SUPPLY terminals of the flowmeter in the version with a low-voltage power supply, as this will damage it.

7.1. Connecting the sensor signal cable

The signals that are transmitted from the sensor electrode circuit to the transmitter have values at the millivolt level. These signals are very sensitive to magnetic and electrostatic interference that can come from adjacent high voltage cables, power cables and power lines feeding high power electrical equipment. The interference is compensated for by the flowmeter's internal noise filter; nevertheless, these unwanted signal sources should be avoided if possible. For the PEM-1000NW flowmeter it is recommended to locate the signal cable from the sensor in separate cable ducts.

The signal cable coming out of the sensor has a special design and is part of the order, therefore its length should not be changed (for a certified instrument it must not be changed).

The cable sheath (insulation) should remain intact along its entire length.

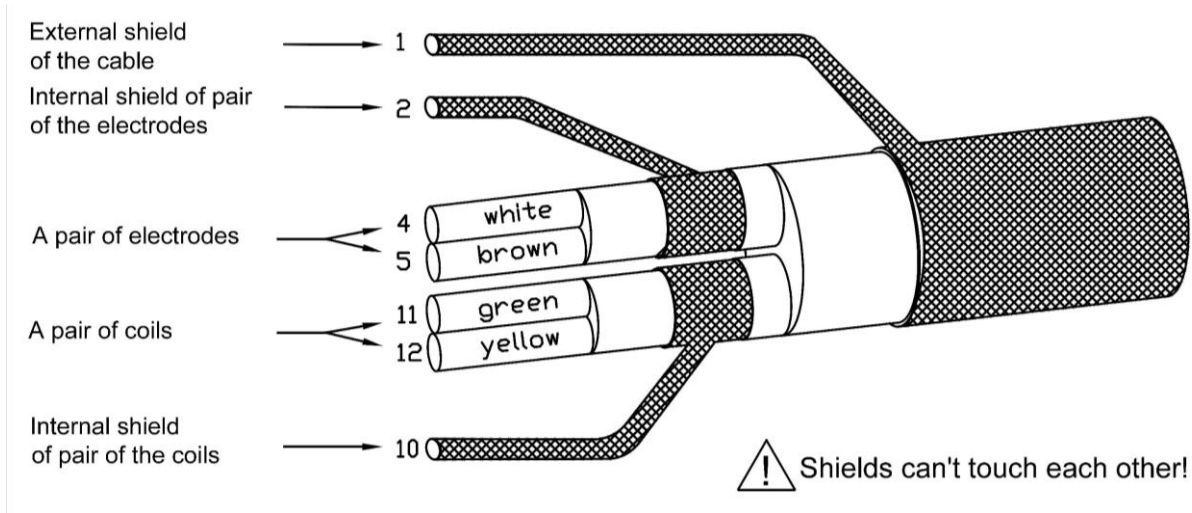

Figure 7. Marking the leads of the sensor cable cores.

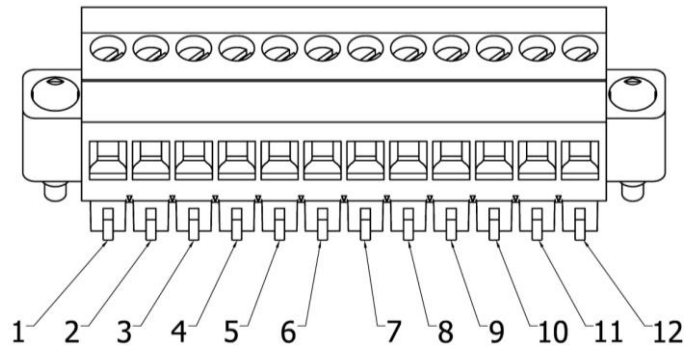

Figure 8. Connection pins of the sensor cable plug.

Table 4. Connection pins of the sensor cable plug.

Socket number / PIN on the plug	Cable core type	Colour of the cable core
1	Cable outer shield or free clamp (depending on sensor type)	-
2	Internal shield of the electrode pair	-
3	-	-
4	Electrode pair	White
5	Electrode pair	Brown
6	-	-
7	-	-
8	-	-
9	-	-
10	Internal screen of the coil pair	-
11	Coil pair	Green
12	Coil pair	Yellow

The wires of the sensor cable should be connected to the plug in accordance with the instructions in Figure 10 and the PIN description in Table 2.



Incorrect connection of the cable cores to the transducer plug will cause many measurement errors.

7.2. Grounding



The flowmeter must be earthed according to the rules in force at the place of installation. The lack of functional grounding can cause significant disturbances in the measurements.

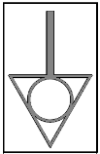

Marking of the connection point of the functional earth of the flowmeter.



Marking of the protective ground connection in the transmitter housing.

7.2.1. Protective grounding



Protective grounding is an element ensuring safety against electric shock in accordance with the standards and must always be connected.

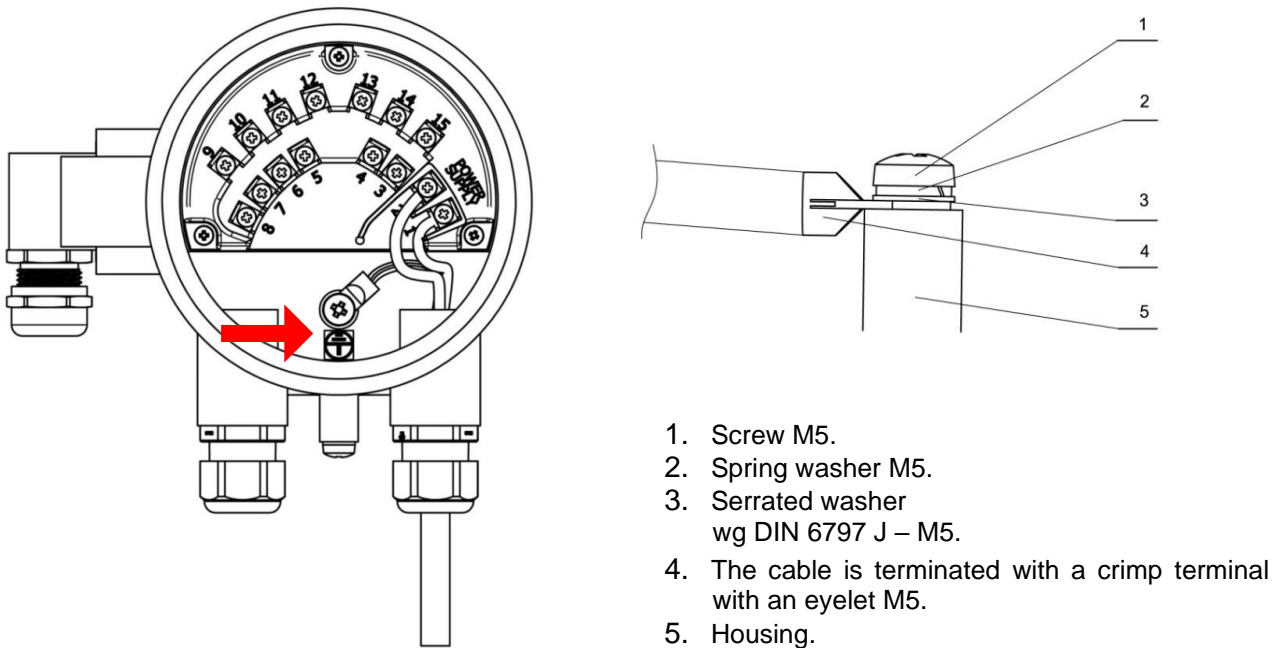

Figure 9. Location and method of connecting the protective earth to the transmitter housing.

Use a power cable suitable for the cable gland, with certified cables with a working voltage of 300/500 V.

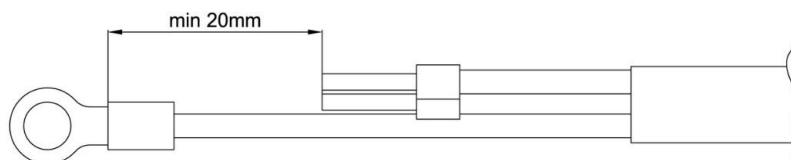

Figure 10. Proper preparation of the power cable.



In order to maintain safety, the power cable should be prepared in such a way that the earth wire (yellow-green) is longer than the other wires by min. 20mm. The end of the earthing wire should be extended with a tip with an eyelet to the M5 screw. Crimp the end on the earthing conductor with a cable crimper.

7.2.2. Functional grounding



Functional grounding ensures the equalization of the potentials of the transmitter, sensor, pipeline and liquid, enabling the correct performance of measurements.

The transmitter housing should always be connected to the sensor housing and connected to the sensor grounding point as shown in the figures below. This is particularly important when installing the flowmeter in a remote version (NW). The grounding point of the sensor should be connected to the metal pipeline or to the grounding rings in the case of non-conductive pipelines.

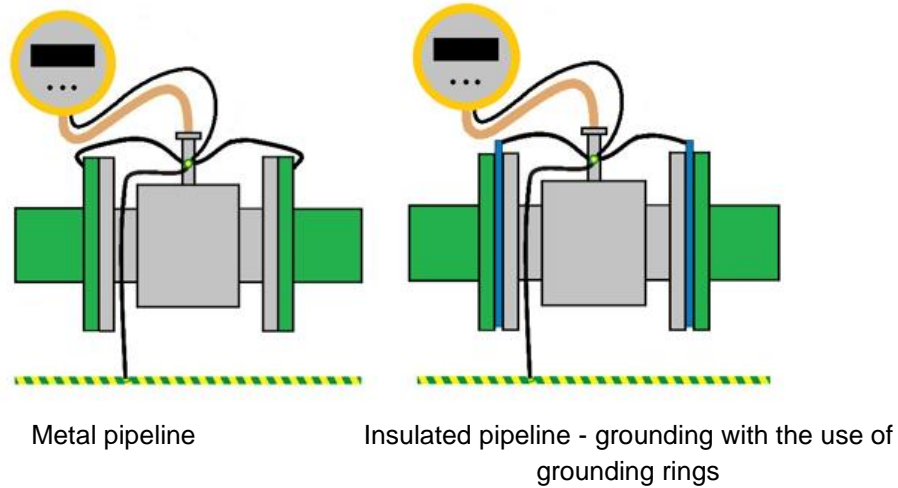

Figure 11. Example of a functional earthing connection for a metal pipeline and for an insulated pipeline using earthing rings.



To properly ground the flowmeter, refer to the graph in Figure 16.

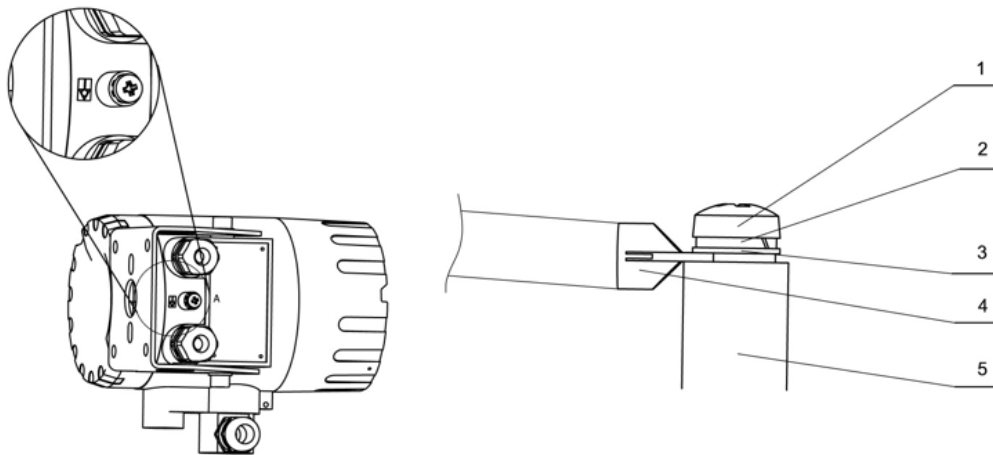
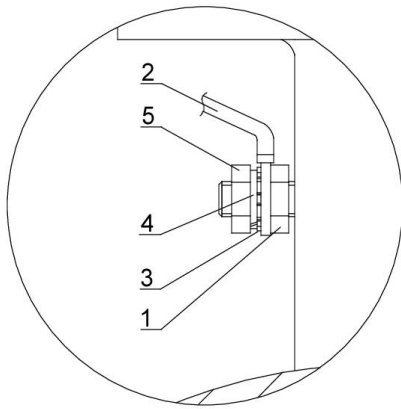

Figure 12. The way of connecting the functional ground to the transmitter housing.

The sequence of elements in the properly made earth connection of the transmitter:

1. Screw M5.
2. Spring washer M5.
3. Serrated washer acc. DIN 6797 J – M5.
4. The cable is terminated with a crimp terminal with an eyelet M5.
5. Housing.



Connection elements in the order of assembly:

1. Screw M6.
2. The cable is terminated with a crimp terminal with an eyelet M6.
3. Serrated washer acc. DIN 6797 J – M6.
4. Spring washer M6.
5. Nut M6.

Figure 13. The method of connecting functional ground to the sensor housing.

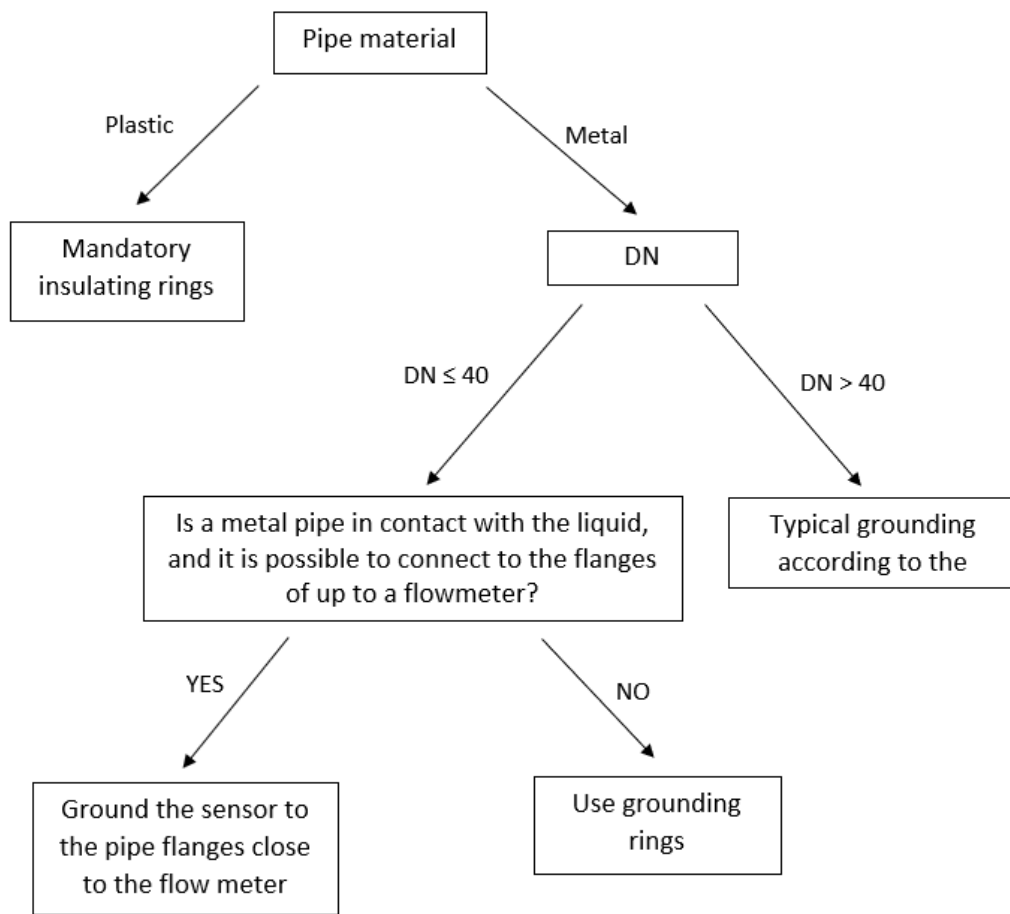

Figure 14. Graph of correct functional grounding of the PEM-1000 flowmeter.

8. START-UP

After assembly and electrical connection of the flowmeter must be checked installation and connections as follows:

- tighten all cable connections, terminals and plugs in all connectors and verify the earth connection;
- verify the correctness of the electric supply in accordance with the information on the rating plate of the device;
- verify the installation's protection against electric shock;
- check the correct installation of the flowmeter in the pipeline (no play, gaps);
- if no defects or damage are found in the installation, fill the pipeline with liquid and verify its tightness. After a short flushing, switch the system on-off-on and start the measurement.



The description of the device configuration can be found in the EN.IK.PEM-1000 manual, and the description of Modbus communication in the IM.PEM-1000(ENG) manual. The documentation is available on the manufacturer's website www.aplisens.com

9. TECHNICAL PARAMETER

9.1. Protection class

The device has protection class I, a protective conductor has been led out and connected inside the housing. The measuring circuits (to the sensor) are separated from hazardous voltages by reinforced insulation in accordance with the requirements of PN-EN 61010-1.

9.2. Technical specification

Table 5. Technical data of the sensor and transmitter.

Technical data			
Transmitter		Sensor	
Electrical conductivity of the medium	≥ 5 μS/cm	Nominal size	DN 10...1000, (ANSI 0.5" ... 40")
Input resistance	≥ 10 ¹⁰ Ω	Max static pressure	Standard 1,6 MPa (2,5 MPa, 4 MPa)
Accuracy*	±0,5% of reading at 20...100% Qmax ±1% of reading at 10...20% Qmax	Process connection	Flange DIN ANSI
Low flow rejection	Adjustable value	Ambient temperature	-20...60°C
Actual flow	both directions (l/s, m ³ /h, m ³ /s, other)	Liner temperature range	Rubber: -5...90°C Teflon: -25...130°C
Totalizer	3 counters, total, positive, negative (m ³ , other)	Connection cable	Standard 8m (other on request)
Low flow alarm	Adjustable, any value	Electrodes material	Stal 316L (Hastelloy, Tantal, Titan, Platin)
Configuration	LCD display/buttons or Modbus RTU via RS485	Flow tube material	Stal 321
Empty pipe detection	Cyclic, configurable	Insulation lining	Hard rubber DN20...1000 Teflon DN10...500 Halar ECTFE DN350...600
Analog output	4...20 mA/500Ω Active output (passive – on request)	Casing and flange material	Carbon steel (steel 304, steel 321)
Pulse/frequency output	Max. 24 V/10mA DC; 0,1...2000 Hz in frequency mode; up to 500Hz in pulse mode.	Corrosion protection	Acrymetal varnish
2-state output OC	2; open collector Max. 35 V DC for each galvanic insulation; reverse polarity protection	Accessories	Grounding rings
Communication output	Modbus RTU/RS 485 Galvanic insulation	Excitation coils supply	From the transmitter
2-state input	5...35 V DC/2 mA Passive input, galvanic insulation, reverse polarity protection	Excitation of coils isolation class	E
Power supply	90...260 V AC/ 50Hz/15 VA 10...36 V DC / 15W (reverse polarity protection)	Protection class	IP67 (IP68-on request)
IP range	IP66 (IP67-on request)	Measuring principle	Electromagnetic
Ambient temperature	-20...60°C	Execution on request of sensor	Stainless steel Hygienic connection
Weight	3,5 kg	Weight	acc. to data in the catalogue

9.3. Technical specification

Flow	0,3 – 12 m/s
Measured medium	Water 10 – 30°C
Conductivity	> 300 μ S/cm
Supply variability	$U_n \pm 2\%$ (U_n – power supply voltage)
Ambient temperature	18 - 25°C, constant humidity
Stabilization time after switching on power	Min. 20 min
Straight flow sections	5DN in front of the sensor, 3DN behind the sensor
Measuring sensor	Combined with the transmitter, positioned centrally under with the guidelines contained in the manual

ATTENTION! Reference conditions generally contain reference values or reference ranges for influencing quantities that affect the flowmeter.

9.4. Metrological parameters

The **PEM-1000** flowmeter is made in the range of the size of flange connections defined by the DIN standard in the range of DN10 ÷ DN1000 or, optionally, in the size range of flange connections according to the ANSI, BS standard. Standard flow rates for individual versions of the flowmeter with flange connections according to DIN in the range DN10 ÷ DN1000 are presented in the table below. It is possible to set other values of the **Q_{max}** flow for individual versions of the flowmeter.

Table 6. Flow values for the PEM-1000 flowmeter.

Flow values							
DN acc. DIN	Recommended flow limits		Factory settings				
	$\sim Q_{(min)}$	$\sim Q_{(max)}$	Analog output 4...20 mA		Pulse output		Low flow cut-off ($v \sim 0,1$ [m/s])
			Measuring range	Linear flow velocity (to the end of the measuring range)	Volume/pulse	Number of pulse / m ³	
	[m ³ /h]	[m ³ /h]	[m ³ /h]	[m/s]	[m ³ /impulse]		[m ³ /h]
10	0,08	2,8	0÷1	3,54	0,000025	400000	0,03
15	0,19	6,4	0÷2	3,14	0,000005	200000	0,06
20	0,34	11	0÷4	3,54	0,00001	100000	0,12
25	0,5	18	0÷5	2,83	0,0000125	80000	0,15
32	0,9	29	0÷10	3,45	0,000025	40000	0,3
40	1,4	45	0÷15	3,32	0,00004	25000	0,45
50	2,1	71	0÷20	2,83	0,00005	20000	0,6
65	3,6	119	0÷30	2,51	0,0001	10000	0,9
80	5	181	0÷50	2,76	0,000125	8000	1,5
100	8	283	0÷100	3,54	0,00025	4000	3
125	13	442	0÷150	3,40	0,0004	2500	4,5
150	19	636	0÷200	3,14	0,0005	2000	6
200	34	1131	0÷360	3,18	0,001	1000	10,8
250	53	1767	0÷500	2,83	0,00125	800	15
300	76	2545	0÷760	2,99	0,002	500	22,8
350	104	3464	0÷1000	2,89	0,0025	400	30
400	136	4524	0÷1300	2,87	0,004	250	39
500	212	7069	0÷2000	2,83	0,005	200	60
600	305	10179	0÷3000	2,95	0,008	125	90
800	416	13854	0÷5000	2,76	0,0125	80	120
1000	848	28274	0÷8000	2,83	0,025	40	240

9.5. Table of volumetric flows calculated for the characteristic flow velocities of the medium for versions with flanges according to DIN.

The volumetric flow is calculated from the measured linear velocity of the flow and the cross-sectional geometry of the flowmeter. The table shows the values of volumetric flows for individual DN's at characteristic linear flow velocities.

Table 7. Volumetric flow as a function of the linear velocity of the medium.

DN	Flow speed V [m/s]							Flow rate [m ³ /h]
	0,300	1,000	2,000	3,000	4,000	5,000	6,000	
10	0,085	0,283	0,565	0,848	1,131	1,414	1,696	
15	0,191	0,636	1,272	1,909	2,545	3,181	3,817	
20	0,339	1,131	2,262	3,393	4,524	5,655	6,786	
25	0,530	1,767	3,534	5,301	7,069	8,836	10,603	
32	0,869	2,895	5,791	8,686	11,581	14,476	17,372	
40	1,357	4,524	9,048	13,572	18,096	22,619	27,143	
50	2,121	7,069	14,137	21,206	28,274	35,343	42,411	
65	3,584	11,946	23,892	35,838	47,784	59,729	71,675	
80	5,429	18,096	36,191	54,287	72,382	90,478	108,573	
100	8,482	28,274	56,549	84,823	113,097	141,372	169,646	
125	13,254	44,179	88,357	132,536	176,714	220,893	265,072	
150	19,085	63,617	127,234	190,852	254,469	318,086	381,703	
200	33,929	113,097	226,194	339,292	452,389	565,486	678,583	
250	53,014	176,714	353,429	530,143	706,858	883,572	1060,287	
300	76,341	254,469	508,938	763,406	1017,875	1272,344	1526,813	
350	103,908	346,360	692,721	1039,081	1385,441	1731,801	2078,162	
400	135,717	452,389	904,778	1357,167	1809,556	2261,945	2714,334	
500	212,057	706,858	1413,716	2120,573	2827,431	3534,289	4241,147	
600	305,363	1017,875	2035,750	3053,625	4071,501	5089,376	6107,251	
800	542,867	1809,556	3619,112	5428,668	7238,223	9047,779	10857,335	
1000	848,229	2827,431	5654,862	8482,293	11309,724	14137,155	16964,586	

Table 8. Flow values corresponding to a speed of 1 m/s.

Flow values corresponding to speed of 1 m/s			
DN	m ³ /h	l/min.	l/s
10	0,283	4,712	0,079
15	0,637	10,62	0,177
20	1,131	18,85	0,314
25	1,767	29,452	0,491
32	2,895	48,255	0,804
40	4,524	75,398	1,257
50	7,069	117,81	1,964
65	11,946	199,1	3,318
80	18,096	301,59	5,027
100	28,274	471,23	7,854
125	44,179	736,31	12,272
150	63,617	1060,3	17,671
200	113,10	1885	31,42
250	176,71	2945,2	49,087
300	254,47	4241,2	70,686
350	346,36	5772,7	96,211
400	452,39	7539,8	125,66
450	572,26	9537,5	158,96
500	706,86	11781	196,35
600	1017,9	16965	282,74
700	1384,7	23079	384,65
800	1809,6	30159	502,65
900	2289,1	38151	635,85
1000	2827,4	47124	785,4

9.5.1. Selection of flowmeter diameter and measuring range

The selection of the appropriate diameter of the flowmeter depends on the diameter of the pipeline on which it will be installed, as well as the value of the flow of liquid flowing in this pipeline. The minimum measuring range of a given flowmeter corresponds to a linear liquid flow velocity of 0.3 m/s, while the maximum measuring range is for a liquid flow of 10 m/s. The optimal measuring ranges correspond to the linear velocities of the liquid flow from 2 to 6 m/s. Factory-set measuring ranges taking into account the optimal linear flow velocities are given in → [Table 6](#). Measurement at liquid linear velocity of less than 0.1 m/s is not recommended.

The factory calibration of the flowmeter is performed at a flow velocity of about 6 m/s, and its result is given on the calibration certificate, which is supplied with the flowmeter. The flow velocity should also take into account the physical properties of the liquid. For erosive liquids such as water with sand or gravel, milk of lime, speeds below 2 m/s are recommended. Sludge-forming liquids, e.g. sewage sludge, should move at a speed greater than 2 m/s during the measurement.

Selection of the measuring range of the flowmeter (applies to liquid flow in both directions)

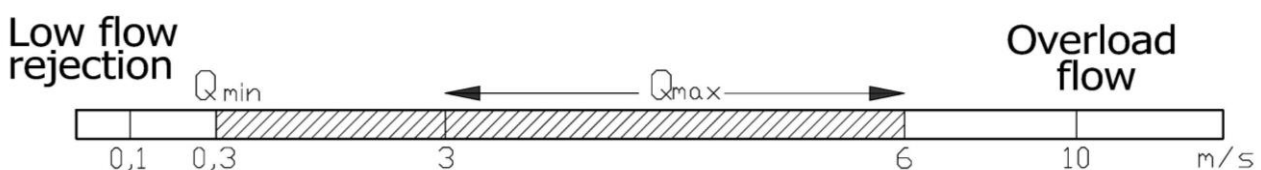
**Figure 15.** Recommended flow values of the PEM-1000 flowmeter.

The mapping of the instantaneous flow value with the 4...20 mA current signal is limited to the flow range determined by the MIN value and MAX value parameters (in the same unit as set in the Flow unit option) included in the Outputs config parameter subgroup.

"Flow value for 4 mA current" and "Flow value for 20 mA current" (in the same unit as set in the "Flow unit" option in the "Basic" tab).

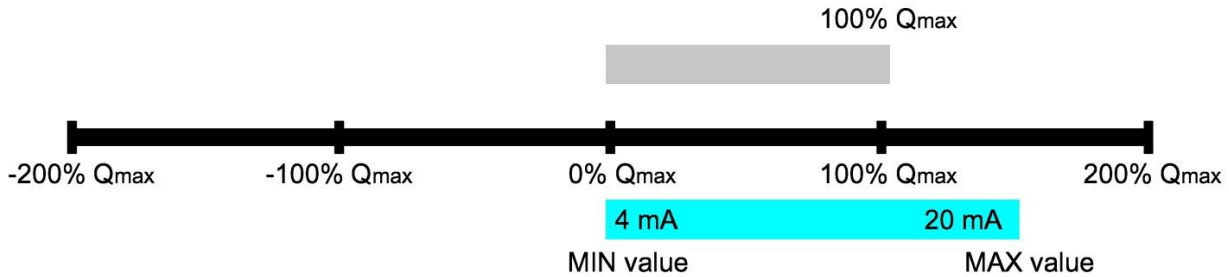

Figure 16. The measuring range of the flowmeter is determined by the Qmax parameter.



The manufacturer guarantees that the declared accuracy class will be maintained in the range of 10% to 100% Qmax.

10. MAINTANANCE

10.1. Periodic inspections

Periodic inspections should be performed in accordance with the standards applicable to the user. During the inspection, the condition of the electrical connections and the stability of the flowmeter mounting should be checked.

10.2. Non-periodic inspections

If the flowmeter in the place of installation has been exposed to mechanical damage, electrical surges or incorrect operation is found, the device should be inspected. If there is no signal in the measurement line or its value is incorrect, check the condition of the cable, the condition of connections on the terminals, etc. Check whether the value of the supply voltage and the load resistance are correct. If the line is in working order, check the operation of the flow-meter.

10.3. Cleaning/Washing

Immediately after the delivery of the electrodes do not have to be cleaned before installation in the pipeline. It is best to use a clean cloth or rag and detergent to clean the electrodes. Damage to the floor covering should be avoided. If the electrodes need to be cleaned during operation, mechanical and electrolytic methods can also be used. Mechanical cleaning may only be performed with the use of an appropriate instrument suitable for the sensor, otherwise the flowmeter must be removed from the pipeline. After cleaning, reinstall the flowmeter. In most cases, the flowmeter does not require cleaning throughout the service life, it is self-cleaning by flowing liquid. This process is particularly effective at flow velocities of about 3 m/s.



In the case of installations intended for the measurement of viscous or heavily contaminated substances, it is suggested to install two oblique tees with inspection covers (in front of and behind the flowmeter), which will allow cleaning the device without the need to disassemble.

11. TROUBLESHOOTING

11.1. Measurement board error E_FE_xx

The table below refers to errors reported by the measuring board, signalled on the main screen with the message E_FE_xx, where xx is a hexadecimal number (hexadecimal) denoting the error code. This code consists of eight bits denoting different statuses listed in the table. A single digit of the code corresponds to four consecutive bits (the older digit is bits 7-4, the younger bits 3-0). Successive hexadecimal digit values and corresponding bit combinations are:

digit	0	1	2	3	4	5	6	7	8	9	A	B	C	D	E	F
bits	0000	0001	0010	0011	0100	0101	0110	0111	1000	1001	1010	1011	1100	1101	1110	1111

Table 9. Error descriptions of the PEM-1000 flowmeter and their possible solutions.

	Error description	Possible solution
bit 7 (0x80)	Electrode differential voltage (coarse offset) exceeded	<ol style="list-style-type: none"> 1. Check the installation for air lock. 2. Check the grounding system of the sensor and the pipes near the sensor. 3. Check if the liquid in the vicinity of the sensor does not come into contact with metal parts at a potential other than earth. Ground the isolated metal sections (pipes, valves) to the sensor's functional grounding system. 4. Check if the electrodes are not covered with deposits that prevent their contact with the liquid. 5. Verify by visual inspection of the installation if there are no significant stray currents in the fluid or pipes, e.g. from galvanizing equipment, high-power pump motors, protective and neutral earth conductors of high-current wiring, etc. <p>Note! The voltages at the electrodes can be checked in the diagnostic menu, screen 1.</p>
bit 6 (0x40)	ADC flow measurement transducer does not respond	Check for other errors related to voltage overshoots (on bit 7 and/or 1), and if none, return the flowmeter to the manufacturer or authorized representative.
bit 5 (0x20)	Incorrect resistance of the sensor coil	<ol style="list-style-type: none"> 1. Verify if the operating temperature of the sensor does not exceed the maximum permissible value. 2. Check if there is an error of incorrect sensor coil current (bit 4), and if yes, switch off the flow meter, dismantle the electronic module, disconnect the signal connector (green 12-pin connector) and measure the resistance between terminals 11 and 12 (yellow and green wires are connected there). The resistance should not exceed 120 Ω and in case of increased temperature of the measured medium – 145 Ω. If the resistance is significantly higher, the sensor or the signal wire to the sensor (for the split version) is damaged.
bit 4 (0x10)	Incorrect sensor coil current	Check the resistance of the sensor coil in the diagnostic menu (screen 3, item Rcoil), if it is greater than 140 Ω, proceed as in the case of an incorrect sensor coil resistance error (bit 5). If the resistance is lower and the sensor is DN200 or larger, check the value of parameter "FI" on diagnostic screen 3. The parameter should have four digits and the first digit should be 1. If this is not the case, contact the manufacturer or, if necessary, send the electronic module back to the manufacturer or an authorised representative for reconfiguration.
bit 3 (0x08)	Absolute voltage of electrode 3 (auxiliary) exceeded	-----

bit 2 (0x04)	Absolute voltage of electrode 2 (measuring electrode) exceeded	<ol style="list-style-type: none"> 1. Check the installation for air lock. 2. Check if the electrodes are not covered with deposits that prevent their contact with the liquid. 3. Verify if there is no interruption in the electrode circuit (damage to the signal wire in the split version).
bit 1 (0x02)	Absolute voltage of electrode 1 (measuring electrode) exceeded	
bit 0 (0x01)	The differential (measurement) voltage of the electrodes has been exceeded	<ol style="list-style-type: none"> 1. Check the system for air lock and temporary air lock during operation, e.g. due to foam or air bubbles. Check if the flow sensor has been installed in accordance with the instructions to avoid air lock and if it is in the correct position to ensure that the electrodes are immersed. 2. Check the grounding system of the sensor and the pipes near the sensor. 3. Check if the liquid in the vicinity of the sensor does not come into contact with metal parts at a potential other than earth. Ground the isolated metal sections (pipes, valves) to the sensor's functional grounding system. 4. Check if the electrodes are not covered with deposits that prevent their contact with the liquid. 5. Verify by visual inspection of the installation if there are no stray currents in the liquid or in the pipes that reach the sensor from the ground loop, especially when galvanizing devices, high-power pump motors, protective and neutral conductors of high-current wiring, etc. are nearby. Verify if the protective ground of the flowmeter is connected to its functional ground. 6. Verify if no rapid changes in conductivity or ion concentration occur in the measured medium due to dosing of reactive substances into the pipeline in the close vicinity of the flow sensor. <p>Note! This error is virtually always associated with installation problems. The voltages at the electrodes can be checked in the diagnostic menu, screen 1.</p>

11.2. Sensor error E_SENS_xx

The error is usually related to incorrect results of liquid resistance measurement and may mean a short circuit between one of the measuring electrodes and the ground or reference electrode. An additional effect of this error can be a significant increase in flow measurement error. Contact the service immediately if this error has occurred!

12. SCRAPING, DISPOSAL



Worn or damaged devices shall be scrapped in accordance with WEEE Directive (2012/19/EU) on waste electrical and electronic equipment or returned to the manufacturer.

13. HISTORY OF REVISIONS

Revision No	Document revision	Description of changes
-	01.A.001	First version of the document.
1	01.A.002	Editorial changes.
2	02.A.003	Editorial changes
3	02.A.004/2021.06	First edition of the new version of the document. Editorial changes. Added "Appendix A" Prepared by the DBFD department.

APPENDIX A – Configuration Local MENU Settings

The flowmeter is operated locally by means of three buttons and a display located under the unscrewed display cover.

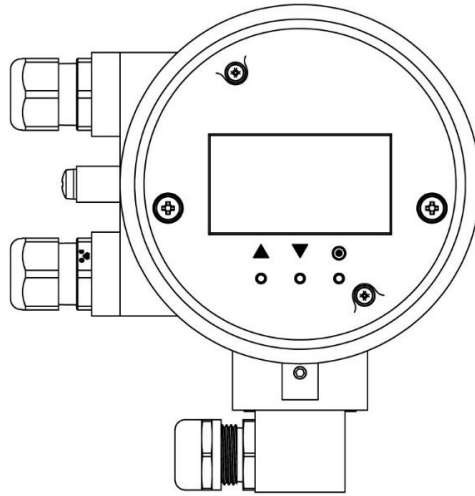

Figure 1. View of local buttons and display of PEM-1000 flowmeter.

The following actions have been assigned to the local buttons marked with respective symbols (depending on the menu item):

- The left button ▲ most often functions as a key to move up, to the left or decrease the value.
- The middle button ▼ most often acts as a key to move down, to the right or increase the value.
- Right button ◻ is most often used as a selection/accept key (*Enter*) or to change the value.

After commissioning, the flowmeter shows the main screen with the flow measurement result in the selected units, the main counter (totalizer) of the liquid volume, the status and auxiliary information line and the date and time.

Press ▲▼ keys to go to the next screens displaying, among others, totalizers, user totalizers and information about firmware versions. After 3 minutes of inactivity, it automatically returns to the main screen.

1. Login with different levels of authorization

Logging into the menu is only possible from the main screen. Hold down the key ⊙ until the login screen appears, where you enter your PIN. Individual digits are edited with the key ⊙ and the cursor moves with the ▲▼ keys. Only the currently edited digit is exposed, the others are replaced by asterisks. After moving the cursor to the extreme right position (where the Enter option appears) and pressing ⊙ the PIN code is entered, which enables access to the User or Administrator menu. If the PIN is incorrect, you will return to the main screen.

Logging into the flowmeter menu with different levels of function authorization is done by entering the appropriate four-digit PIN:

- **USER** – user with limited functionality not having access to selected menu items, the factory set PIN is “1000”.
- **ADMINISTRATOR [A]** – administrator with full functionality who has no restrictions in access to menu items, the factory set PIN is “1020”.

After logging into the flowmeter menu as **USER** and attempting to select a function with restricted access, the message “**LACK OF ACCESS TO THIS OPTION**” appears on the screen.



Pressing the PL and PP buttons simultaneously for at least 1 second causes a “fast exit” from each menu level directly to the main screen.

The diagrams (→ **APPENDIX B** - Structure of the local MENU) show how to navigate through the local menu structure of the PEM-1000 flowmeter.



It is not recommended to make any changes in the “Calibration” tab as this may result in a distortion of the saved settings and the need to send the device to the manufacturer or an authorised representative. Flow meters are calibrated at the production level, according to the customer’s order.

How to change settings using the local MENU

There are 3 local buttons for changing the settings, i.e. 2 navigation buttons ▲, ▼ and the Enter button ⊙. Depending on the field/function the change is made by selecting the function in the menu using the navigation buttons. Then select the option you are looking for with the Enter button and depending on the field:

- changes can be made by selecting available variants of a given option (scrolling using navigation buttons). Confirm the selection with the Enter button.
- changes may require manual entering of numerical values; in order to do that press the Enter button in the numerical value field, use the navigation buttons to change the cursor position and subsequent clicks on the Enter button will allow you to select the appropriate character among the available ones. After entering the value, move the cursor as far to the right as possible until the “Set” message appears (in the bottom right corner of the screen) and confirm with Enter.

2. Units and display

LOG IN ➡ MENU ➡ DISPLAY ➡ UNITS SET. ➡ TOTALIZERS
FLOW
FLOW RATE
USER DEFINIT.

This function allows the user to define the displayed units by selecting among the available units in the flowmeter menu. The selection is made by pressing the Enter button in the unit field. Use the navigation buttons to find the appropriate unit and then confirm again by pressing the Enter button. Execution of the operation will be confirmed by the “OK” message.

TOTALIZERS – select the volume counter (totalizer) unit.

FLOW – select the flow unit.

FLOW RATE – defining the unit for the linear velocity of fluid flow.

USER DEFINIT. – this function allows you to define your own unit and to assign a user-defined value to it.

3. Filtering

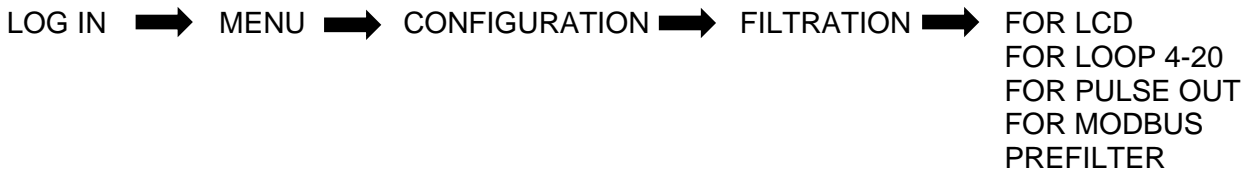

This function allows you to define filtering parameters. To do this use the navigation buttons and the Enter button to select or confirm changes.

Each of the following functions allows you to define the filtering mode (AVERAGE or DUTY) and specify the filtering time (0-60 s, **setting the time to “0” means that filtering is disabled**). The above settings apply to filtering:

- FOR LCD;
- FOR 4-20 [mA] LOOP;
- FOR PULSE OUTPUT;
- FOR MODBUS.

The user can also specify the filtering level for the “PREFILTER” function; to do this, select the function with the Enter button and define the filtering value (0-10) in the “level” field.

The filter type and parameters are set separately for the flow rate presentation channels indicated above. Prefiltration is done independently before the filtration mentioned above, and applies to all channels. Pre-filtering supports the presentation of results under highly disturbed measurement conditions.

4. Units and display

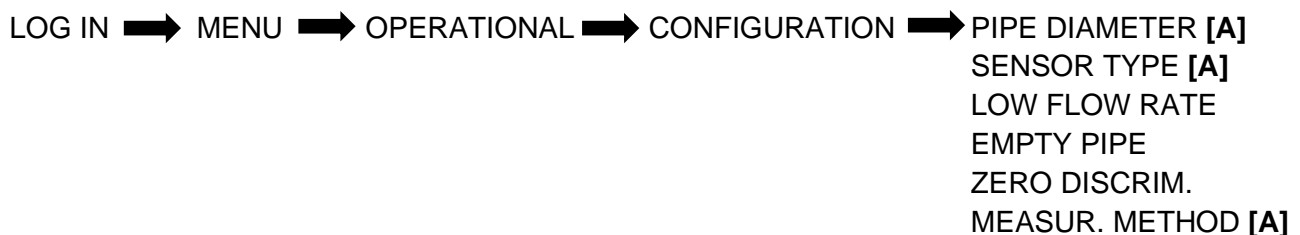

The operational configuration allows you to define the operating parameters of the device. To access a specific menu function, select it using the navigation buttons and then confirm with the Enter button.

PIPE DIAMETER (MENU ITEM ACCESSIBLE FROM THE ADMINISTRATOR LEVEL) – this function enables setting nominal flow sensor pipe diameter. This value is factory set and should always match the actual diameter of the sensor.

SENSOR TYPE (MENU POSITION AVAILABLE FROM THE ADMINISTRATOR LEVEL) – allows the selection of the type of sensor used (selection of a sensor with two or three active electrodes). To make a selection, use the navigation buttons in the “TYPE” field to make the desired choice and then confirm it with the Enter button. Factory set value, typically 2 electrodes.

LOW FLOW RATE– enables switching on/off the function signalling the flow drop below the set value. Detection of this situation results in an indication on the screen and triggering of the internal alarm signal, which can be used to signal an error via e.g. binary outputs. To do this, select the function with the Enter button using the navigation buttons in the “ON/OFF” field to enable or disable the function and then confirm with the Enter button.

The value should be entered manually in the “VALUE” field using the navigation buttons to change the cursor position and the Enter button to change subsequent characters/numbers. Once the value is entered, move the cursor as far to the right as possible until the “Set” message appears and confirm with Enter.

EMPTY PIPE – this function enables setting up the detection of an empty pipe. To do this, select the function with the Enter button. Then, in the “**ON/OFF**” field enable or disable the empty pipe detection using the navigation buttons. The desired selection must be confirmed with the Enter button.

ZERO DISCRIM. – this function causes the flow measurement results smaller than the set value to be replaced by zero. It is used to eliminate noise that occurs at very low or zero flow rates, thereby preventing unnecessary volume accrual under these conditions. The recommended value corresponds to approximately 0.1 m/s linear flow velocity and is given in → [Table 6](#). The function can be turned on or off in the “**ON/OFF**” field using the navigation buttons and the Enter button. In addition, the user should define the cut-off value in the “**VALUE**” field using the navigation buttons to move through consecutive characters and the Enter button to change consecutive characters/numbers.

MEASUR. METHOD – this function enables selection of the measurement mode. In order to do that, select the options in the “**TYPE**” field by means of the Enter button and then, using navigation buttons, choose the appropriate mode from among the available ones, i.e.:

- **Neutral** – used for low density liquids where there are no measurement value spikes;
- **Aggressive** – usually used for high density liquids (pulp – can cause high measurement value differences in a short time). Measurement spikes can also be caused by the nature of the installation, so it is recommended to run an aggressive measurement mode if measurement value spikes or errors occur.

5. MODBUS

LOG IN ➡ MENU ➡ CONFIGURATION ➡ MODBUS [A] ➡ ON/OFF
UNLOCK_WR
ADDRESS
BAUD
PARITY
DATA

To access a specific menu function, select it using the navigation buttons and then confirm with the Enter button.

ON/OFF – used to enable or disable MODBUS communication.

UNLOCK_WR – enable or disable the ability to record data via the MODBUS interface on the flow meter.

ADDRESS – setting the device address in the defined range 1-247.

BAUD – the item is used to select the bus speed from the list of defined speeds in the device.

PARITY – this function serves for the selection of bus parameters from among the defined ones:

- **EVEB_1S (EVEN 1 STOP)** – with parity, one stop bit;
- **ODD_1S (ODD 1 STOP)** – with parity, one stop bit;
- **NOPA_2S (NOPAR 2 STOP)** – without parity, 2 stop bits.

DATA – allows you to match the byte layout of the transmitted 32-bit variables to the standard used in the MODBUS Master device. This is useful due to the lack of standardization of multi-byte data transfer. Use this function when the Master device receives data from a flowmeter but the received values are incorrect. The format of the data bytes transmitted over the MODBUS can be selected from those available:

- **AABBCCDD** – “Little Endian” type format (the simplest “order” of byte transfer (data are stored in RAM));
- **DDCCBBAA** – “Big Endian” type format (a natural byte transfer “order” compliant with the format for representing 32-bit hexadecimal numbers);
- **BBAADDCC** – “reversed” type format (“order” of byte transfer is analogous to the “Big Endian” type but with interchanged halves of a 32-bit hexadecimal number);
- **CCDDAABB** – the least used format for MODBUS byte transfer (least intuitive).

6. Output configuration

LOG IN ➡ MENU ➡ CONFIGURATION ➡ OUTPUTS ➡ 4-20 [mA] LOOP
 PULSE OUTPUT
 STATUS OUTPUTS

To access a specific menu function, select it using the navigation buttons and then confirm with the Enter button. Change the values using the navigation buttons by selecting and confirming with the Enter button. In the case of a manually entered value, the navigation buttons are used to change the cursor position and the Enter button to enter the corresponding character/number.



The flowmeter is equipped with an active current output, which means that the loop is powered by approximately 24 V from the flow meter. The loop must not be powered from an external power supply. The flowmeter with passive loop 4...20 mA is available as a special version.

4-20 [mA] LOOP – the function allows to configure the 4...20 mA loop. The user can enable or disable the function in the “ON/OFF” field. Define the mode from among the available options:

- **NORMAL** – currents proportional to flow value settings;
- **INVERTED** – currents inversely proportional to the flow value (multiplied * -1);
- **MODULO** – currents proportional to the absolute value of the flow.

In the “**VALUE**” field, define the flow value for 4 mA and 20 mA current respectively. The value should be entered manually using the navigation buttons to move through the consecutive characters, while the Enter button is used to enter the available characters/numbers one by one. To confirm, use the navigation buttons to the right until the command “**SET**” appears and then press Enter to confirm.

The user can enable or disable alarming in the “**ON/OFF**” field in the “**ALARM**” field. This option is used to signal alarm situations occurring in the flowmeter using a 4...20 mA loop, resulting in a status other than “OK”. You can set the following ways for the output to respond to an alarm:

- **LOW** – alarm current of 3.75 mA (constant, specified by the manufacturer);
- **HIGH** – alarm current of 21.6 mA (constant, specified by the manufacturer);
- **CUSTOM** – user alarm must be entered manually in the “**VALUE**” field (usable) alarm using the navigation buttons to move and the Enter button to enter the available characters in sequence (the current defined by the user using the **VALUE** option will be issued);
- **LAST VAL** – current corresponding to the last recorded flow value before occurrence of the alarm situation (“freezing” of the current for the alarm time).

PULSE OUTPUT – pulse/frequency output configuration. To enable or disable the function, select the “**ON/OFF**” field by pressing the Enter key and then use the navigation keys to select the appropriate option.

The “**Mode**” option allows you to select the working mode of the output.

- **Pulse** – pulse output. Volume measurement of liquids with high accuracy and resolution. Pulses are issued after measuring a unit volume of liquid, defined by the Value/pulse parameter. The following settings are available for the pulse output:
 - **Volume/imp** – this is the volume of liquid per 1 pulse. The smaller the value the higher the pulse frequency for a given flow rate. The value entered should be between 0.0000001 and 9999999 (with the possibility of setting the value to 0). To enter a value, select the “**VALUE/PULSE**” function and then press Enter in the input field.
 - **Pulse time** – pulse duration in [ms] in the range 1-10000 [ms]. The longer the pulse the lower the maximum pulse frequency of the output.
 - **Mode** - the device has 3 defined modes of operation:
 - **POSITIVE** – pulses are generated only for positive flow values. Backflow causes a corresponding reduction in the number of pulses issued for positive flow.
 - **NEGATIVE** – impulses are generated only for negative (reverse) flow, positive flow causes decrease of these impulses.

- **MODULO** – impulses are generated for both flow directions, while the direction distinction is possible using the binary output set to the “**PULSE DIR.**”) mode.
- **Polarity** – pulse polarity (positive means activation of the output during the pulse).



The maximum output pulse frequency is 500 Hz as long as a pulse time of 1 ms is set. Exceeding this frequency can cause neighbouring pulses to “stick together” and accuracy to drop. To prevent this the set parameters must satisfy the relation:

$$\frac{Q_{MAX} \left[\frac{m^3}{h} \right]}{Value/pulse [m^3] * 3600} < \frac{1000}{Pulse\ time [ms] + 1}$$

- **PWM** – frequency output. The frequency of the output signal is proportional to the flow value, starting at 0.1 Hz. Use the “**POLAR**” setting to set the signal polarity. Two processing characteristic points are defined using the “**VALUE**” menu:
 - Flow value corresponding to a frequency of 2 kHz (the “**Value min.**” parameter).
 - Flow value corresponding to a frequency of 1 Hz (the “**Value max**” parameter).



The pulse mode of the output allows for precise volume measurement, so that the instantaneous frequency of the output signal may vary by steps within certain limits. The frequency mode (PWM), on the other hand, provides an accurate representation of instantaneous flow values, but should not be used for precise volume measurements.

STATUS OUTPUTS – the user has two status outputs (“**Status 1**” and “**Status 2**”) available.



The following settings are analogous for both status outputs.

To activate or deactivate the status output, select the appropriate option in the “**ON/OFF**” field. The status field menu allows you to define the function (mode of operation) from among the available options:

- **Empty Pipe** – signalling of an empty pipe;
- **Low flow** – signalling of low flow;
- **Unfil.pipe** – signalling of a pipe that is not full of fluid;
- **Errors all** – error signalling (Front End, sensor, memory);
- **Coil Error** - signalling a coil error;
- **I saturat.** – signalling of the current loop saturation;
- **Direction** – signalling of the fluid flow direction (controlling the output for positive flow);
- **Q > value** – signalling of a flow higher than the assumed value;
- **Q < value** – signalling of a flow lower than the assumed value;
- **TP > value** – signalling of an excess of the assumed flow value by the user’s positive counter (in flow units configured in the menu);
- **TM > value** – signalling of an excess of the assumed flow value by the user’s negative counter (in flow units configured in the menu);
- **Dosing** – dosing function, output controlled for the time of measuring the set flow rate;
- **Pulse dir.** – signalling of the direction of liquid flow for bi-directional pulse output operation mode (output control for positive flow), in this operation mode the status output works in synchronization with the pulse output ignoring the delay times set in the “**DELAY**” field. The operator can also define polarisation in the “**POLAR**” field from the “**STATUS OUTPUTS**” menu (“**Positive**”, “**Negative**”) and the delay in the “**DELAY**” field in the range of 0-3600 seconds.

The “**VALUE**” field allows you to define a value for the status output. It is available depending on the selected mode; the unit for the field is in accordance with the set mode (e.g. for the selected option “Q < value” the device determines the flow unit: [m³/h]).

7. Deleting user totalizers

LOG IN → MENU → RESET COUNTERS → TOTALIZERS
 COUNTER TIME
 ERRORS

Using the navigation buttons and the Enter button, select the desired MENU item and confirm. Then select the “DELETE” field and confirm with ENTER. The procedure applies to each of the following MENU items.

TOTALIZERS – the function allows you to delete user counters.

COUNTER TIME – the function enables to delete the working time counter (user).

ERRORS – the function allows you to clear status errors on the device.

8. Diagnostic screens

Flow meters with software newer than 2.7.0790 have the ability to view important diagnostic data available from the flowmeter menu.

To access the diagnostic screens, log in to the flowmeter menu as the Administrator. Use the navigation buttons to find the “DIAGNOSTICS” menu item (last item in the menu) and select it using the Enter button. Then find the item called “Info data” with four consecutive numbers (the tabs contain useful diagnostic information):

“**Info data 1**” – contains electrode voltages (Ue3 is the voltage of the third active electrode, which is not used in most designs).

- Voltages around ± 0.05000 V are suitable for conventional operation;
- Values higher than ± 0.10000 V are subject to aggressive measurement mode setting;
- Voltages higher than ± 1.00000 V usually result from improper grounding, sensor malfunction, or extreme dirt on the electrodes. In case of doubt it is recommended to contact the manufacturer.

```
Ue1= +0.03423
Ue2= +0.02321
Ue3= +0.00220
```

Figure 2. Example of the diagnostic screen on the “Info data 1” tab.

“**Info data 2**” – contains resistance values of individual electrodes – these parameters are of lesser importance (Re3 refers to the third electrode, which should be ignored). When flags are set to 0x0280 or aggressive measurement mode, the screen is not refreshed and values displayed may be 0.

- Values higher than 50000 are the result of contamination or high voltage of the electrodes; in this situation use the “**Info data 1**” instruction.

```
Re1= 4621
Re2= 5768
Re3= 0
```

Figure 3. Example of the diagnostic screen on the “Info data 2” tab.

“**Info data 3**” – contains information about the resistance of the sensor coil, the internal system value – “Fd” and the current state of the system – “FI”.

- The resistance value should be between 100-130 Ω . If the value exceeds these limits there is a problem with the sensor coil or wiring and E_COIL or E_FE_10 errors may occur.
- The internal value of the system usually fluctuates constantly, and in case of problems with the flowmeter it is worth noting down the values read.
- The “F1” parameter is the current state of the system flag, and system flags should be visible here.

```
Rcoil= 112.254  
Fd= 8025  
F1= 1280
```

Figure 4. Example of the diagnostic screen on the “Info data 3” tab.

“Info data 4” – shows the voltages of the electrodes – when the empty pipe detection function is enabled. When the function is disabled, the voltage values are equal to 0. In case of inadequate performance of the empty pipe detection function, it is recommended to make a note of the electrode readings.

```
Uem1= +0.03123  
Uem2= +0.02721  
Uem3= +0.00220
```

Figure 5. Example of the diagnostic screen in the “Info data 4” tab.

APPENDIX B - Structure of the local MENU

